



GHGT-12

Performance and modelling of the pre-combustion capture pilot plant at the Buggenum IGCC

K. Damen^{a*}, R. Faber^a, R. Gnutek^a, H.A.J. van Dijk^b, C. Trapp^c, L. Valenz^d

^a Vattenfall, Engineering and R&D, Amsterdam, The Netherlands/Berlin, Germany

^b Energy research Centre of the Netherlands (ECN), Sustainable Process Technology, Petten, The Netherlands

^c Delft University of Technology, Propulsion and Power, Delft, The Netherlands

^d Institute of Chemical Technology, Prague, Czech Republic

Abstract

This paper summarizes the final results of the pilot plant operation and R&D programme of the CO₂ Catch-up project (2008–2013). The objective of the CO₂ Catch-up project is to demonstrate pre-combustion CO₂ capture at the pilot plant in Buggenum, the Netherlands, in order to verify the technology performance and to generate knowledge in the form of validated models and operational experience.

© 2013 The Authors. Published by Elsevier Ltd.
Selection and peer-review under responsibility of GHGT.

Keywords: Pre-combustion CO₂ capture; pilot plant; Buggenum; IGCC; water-gas shift; absorption

1. Introduction

In 2005, Nuon/Vattenfall initiated the development of a multi-fuel Integrated Gasification Combined Cycle (IGCC) power plant, the so-called Magnum project, in Eemshaven, The Netherlands. The original concept for Magnum was to construct the gasification section first, with the option to install the pre-combustion CO₂ capture

* Corresponding author. Tel.: +31-627845163.
E-mail address: kay.damen@nuon.com

unit afterwards (“capture ready retrofit”). The envisioned pre-combustion CO₂ capture section consists of a water-gas shift (WGS) section to convert CO into CO₂ and H₂ by reaction with steam, CO₂ removal by physical absorption and CO₂ compression. A sweet shift by FeCr-based catalysts was chosen rather than a sour shift by CoMo-based catalysts due to its compatibility for easy CO₂ capture retrofit and the ability to bypass the shift and CO₂ absorption unit (e.g. when CO₂ capture is not economically viable).

This pre-combustion CO₂ capture scheme combines processes that are proven in the chemical industry yet in different configurations. The syngas composition from coal (and biomass) gasification in power applications differs considerably from the syngas resulting from reforming natural gas or heavy oil residues for chemicals production, for which most experience exists [1]. The mode of operation in the power sector also differs from the chemical industry in the sense that the load of the WGS and CO₂ capture unit should follow the ramping of the power plant. Moreover, the WGS section is not designed for maximum H₂ yield but rather to minimize the energy penalty caused by CO₂ capture. Therefore, Nuon/Vattenfall decided to demonstrate and optimize the pre-combustion CO₂ capture concept at a small scale first before full-scale commercial application at the Magnum plant could be considered. This resulted in the so-called CO₂ Catch-up project in 2008, with the objective to demonstrate pre-combustion CO₂ capture at a pilot plant in Buggenum, The Netherlands, in order to verify the technology performance and to generate validated models and operational experience.

2. Pilot plant design

The pilot plant is a simplified, smaller version of the CO₂ capture plant for the Magnum IGCC power plant. It was designed to capture 1.4 t·h⁻¹ of CO₂ from 1.2 t·h⁻¹ of syngas (=0.8% of the syngas flow from the Buggenum gasifier, equivalent to 5 MW_{th}). The pilot plant consists of five sections: syngas conditioning, WGS, condensate recovery, CO₂ absorption and solvent regeneration, and CO₂ compression (see Fig. 1). For more explanation of the process, the reader is referred to [2].

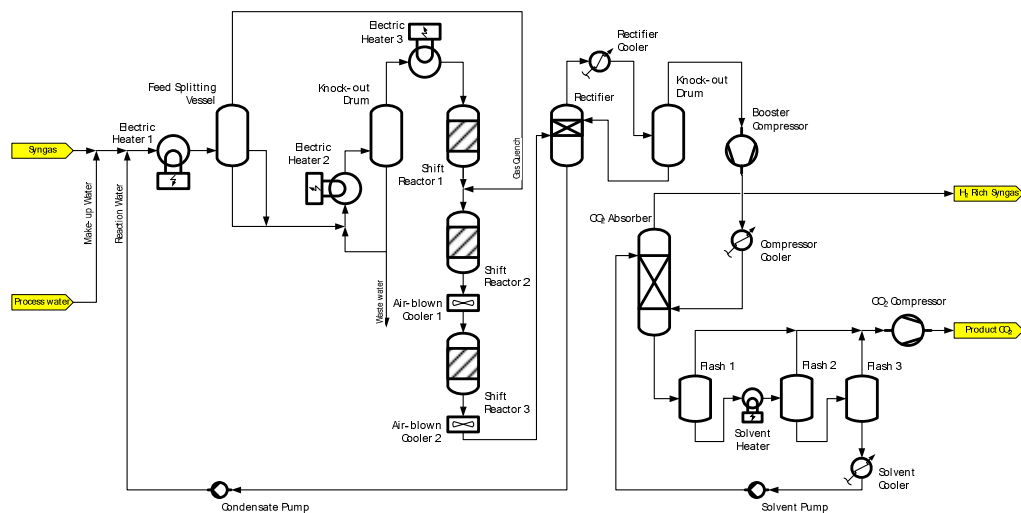

Fig. 1. Simplified process flow diagram of the CO₂ capture pilot plant



Fig. 2. Picture of the pilot plant at the Buggenum power station

3. Pilot plant test programme

The pilot plant has been operated from January 2011 to March 2013, with two major interruptions during summer in which the IGCC was shut down for several months. The plant operated for 5886 hours and the cumulative amount of CO₂ captured is 4478 ton. In this period, various test runs were executed, the results of which are discussed below. During pilot plant operation, no incidents occurred (zero lost time incidents). The pilot plant has been operated without major problems after some (relatively minor) hardware and control modifications, most of them being specific for the pilot plant design. The sampling conditioning system (condensation in the sampling lines) and analyser calibration and operation have been the largest point of concern.

The overall plant mass balance as well as the mass balances for the individual plant sections close very well. For the overall mass balance the relative deviation between input and output is only 0.11% at reference state (i.e. normal operating conditions close to original design point), which is significantly below the measurement accuracy of the individual measurement devices. Also for the sub-sections the mass balances close well (between 2 and 4%).

3.1. Water-gas shift section

The WGS catalyst applied in the pilot plant is Haldor Topsøe's SK-201-2, a copper promoted iron/chromium based high temperature shift catalyst. The overall CO conversion for the entire WGS section is 92-93% at reference state, which is according to design. The axial temperature profiles in the WGS reactors give a good indication whether and at which coordinate equilibrium is reached and how it moves in time and upon changes in process conditions. An optimal operation of the shift reactors could be achieved by adapting the reactor inlet temperatures such that equilibrium is just reached at the end of the catalyst bed. For reactor 1 and 2 the reaction front is well within the catalyst bed and hence the inlet temperature could be decreased versus design (340°C at start-of-run conditions). For reactor 3 the inlet temperature had to be increased to at least 355°C to boost the reaction rate and reach equilibrium.

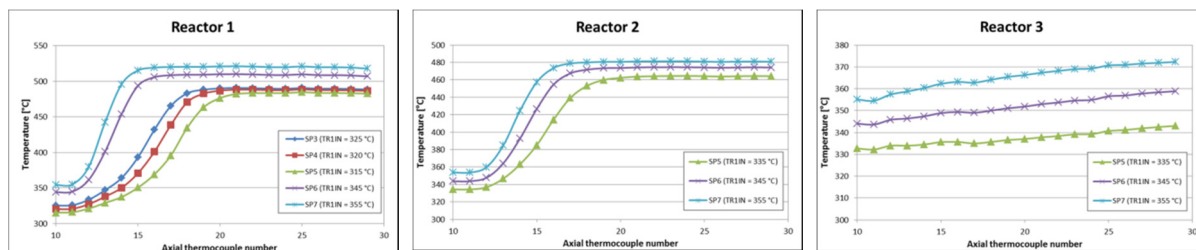

Fig. 3. Axial temperature profiles for reactor 1, 2 and 3 (325 – 355°C)

Analyzing the reference state operation throughout the entire operational period for the WGS reactors by means of modelling of the axial temperature profile yielded insights into the rate of decay of the catalyst activity. Initial rapid deactivation during the first 500 hr operation is observed for reactor 1 and reactor 2. Subsequently, the reactor 1 catalyst activity decreases at a much slower rate than expected. The reactor 2 catalyst first restores its activity after which a decrease in activity is observed at a slower rate compared to reactor 1. The reactor 3 catalyst has a much lower activity than anticipated. Repeated chemical analysis of reactor 3 catalyst samples hinted towards catalyst damage due to an over reduction as being the probable cause for the observed lower activity. This over reduction might result from steam condensation upstream of the reactor during start-up (large heat losses in between reactor 2 and 3 were observed in the commissioning phase), exposing the catalyst to hot dry syngas.

The steam required in the WGS section poses an important contribution to the capture penalty for pre-combustion systems. To this extent, the catalyst behavior towards low-steam operation was studied in the pilot plant. Too dry operation with a high CO content feed risks the reduction of the WGS active magnetite (Fe_3O_4) into iron carbide, being a catalyst for highly exothermal hydrocarbon formation. Besides the undesired high operating temperature, excessive carbiding can physically damage the catalyst pellets. Operation at reduced ratios down to $1.5 \text{ mol} \cdot \text{mol}^{-1}$ indicates that the catalyst does not display progressive carbiding. For a steam/CO ratio of $1.5 \text{ mol} \cdot \text{mol}^{-1}$, the minimal specific energy penalty for CO_2 capture was estimated at $1155 \text{ MJ}_{\text{electric}} \cdot \text{t}_{\text{CO}_2}^{-1}$, which is about 10% lower than the value at design steam/CO ratio of 2.65. The optimum CO_2 capture efficiency, however, also decreases from 87.5% to 78.5% [3,4].

3.2. CO_2 absorption section

The (physical) solvent used to remove CO_2 is dimethyl-ether of poly-ethylene-glycol (DEPEG). Several parametric tests were performed to evaluate the impact on the CO_2 absorption efficiency, validate the mass transfer coefficients and the thermodynamic model (PC-SAFT Equation of State) developed for the solvent and the gas components. Most parametric tests were performed for both random packing Raschig Super-Ring 0.6 and structured packing Raschig Super-Pak 250Y.

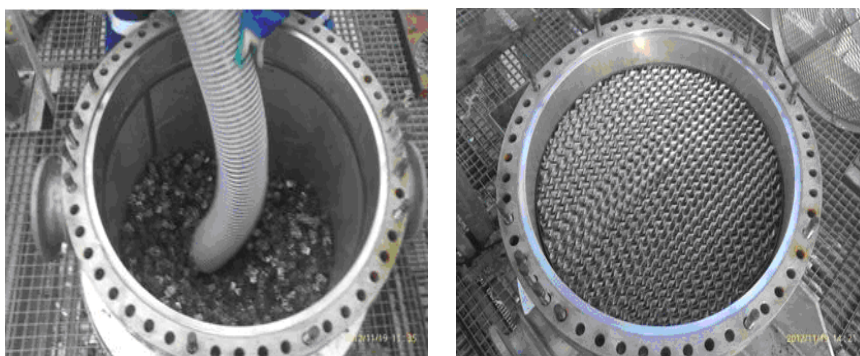

Fig. 4. Raschig Super-Rings 0.6 (left) and Raschig Super-Pak 250 Y (right) in the CO_2 absorber of the pilot plant

The CO₂ absorption efficiency as a function of the solvent mass flow rate is shown in Fig. 5. The CO₂ absorption efficiency is decreasing with the decrease of the solvent mass flow rate which is according expectations. Fig. 6 shows the impact of the syngas mass flow on the absorption efficiency. From this evaluation it seems that the random packing has better absorption efficiency than the structured packing. **Fout! Verwijzingsbron niet gevonden.**

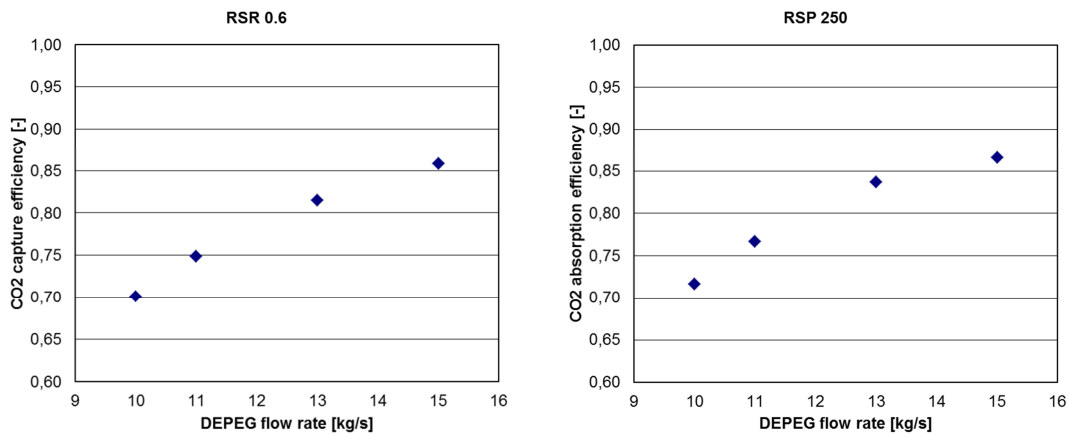

Fig. 5. Dependency of CO₂ absorption efficiency on the solvent mass flow rate for Raschig Super-Rings 0.6 (left) and Raschig Super-Pak 250 Y (right). Note that the absolute values cannot be compared directly due to a different distributor and changed shifted syngas flow rate.

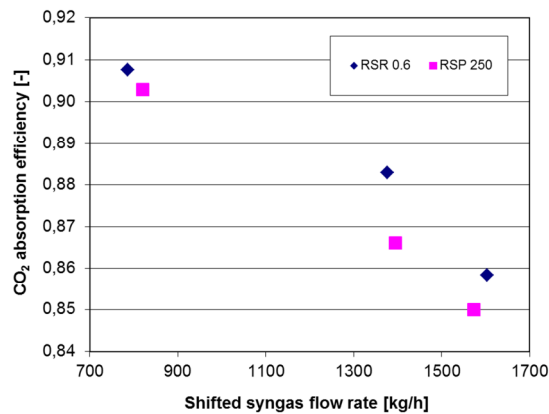

Fig. 6. Dependency of CO₂ absorption efficiency on the syngas mass flow for Raschig Super-Rings 0.6 (blue) and Raschig Super-Pak 250 Y (purple)

The impact of the solvent water content is small; an increase from 1 to 4 wt% decreases the CO₂ absorption efficiency 0.6% absolute. The CO₂ absorption efficiency is increasing with decreasing solvent and shifted syngas temperature and with increasing absorber pressure, due to the higher partial pressure in the gas phase. In addition, tests were performed with extremely high solvent mass flows ($240 \text{ m}^3 \cdot \text{m}^{-2} \cdot \text{h}^{-1}$) as anticipated for the design for the full-scale capture plant. No experiments have been performed at such hydraulic conditions for structured packings. The main objective is to test the column hydraulics and the separation efficiency under these conditions. The test run showed a clear and expected relation between the solvent flow rate and pressure drop for Raschig Super-Ring 0.6. For Raschig Super-Pak 250Y, no sign of flooding of the packing or the distributor can be identified. Towards higher solvent flow rates, the CO₂ concentration at the absorber outlet levels out, indicating that the process becomes limited by mass transfer and no more CO₂ can be absorbed at these conditions.

After the test programme was finished, a sample of fresh solvent (which has not been exposed to process gas) and spent solvent (exposed to process gas for > 5000 hours) was taken for analysis. In comparison to the fresh sample the spent sample has a slightly lowered pH-value (due to the small amount of CO₂ and increased formic acid), a higher water content (which also causes higher viscosity) and a slight shift in homologues. The spent solvent is still in good conditions, which is confirmed by the fact that the solvent performance (as indicated by the capture efficiency) was not deteriorating in time and the solvent physical appearance did not change in time.

4. Process modelling

There are a number of essential differences between the pilot plant and the large-scale capture plant. Due to these differences, the data from the pilot plant cannot be used *directly* to predict the performance of the full-scale plant. The data from the pilot plant are used to validate models, which can be applied for up scaling. By validating the pilot plant models against real operational data, more reliable and accurate models applicable to the large-scale capture plant can be obtained. Below some of the different models developed and results of the process simulations are highlighted. The WGS reactor model is discussed more extensively in [4].

4.1. Steady-state model of the CO₂ absorption section

A model for the absorption and regeneration section has been developed in Aspen Plus V7.3. The model was validated on seven sets of experimental data during which the shifted syngas and solvent flow rate were changed. The model parameters were multiplied constants (C_L and C_V) of the Billet and Schultes mass transfer coefficient correlation [5]. The optimized values of the parameters for random packing Raschig Super-Ring 0.6 are $C_L = 0.1471$ and $C_V = 0.1085$. The absorber outlet molar fractions are on average fitted with an error of 0.72% absolute. The optimized values of the parameters for structured packing Raschig Super-Pak 250 are $C_L = 0.1179$ and $C_V = 0.06242$. The absorber outlet molar fractions are on average fitted with an error of 0.86% absolute. The CO₂ absorption efficiency is predicted with a standard deviation of 0.016 for both packings. The accuracy of the concentration measurements is sufficient in order to get reliable C_L value. The C_V value is much more sensitive to a change in the concentrations used for parameter estimation and is therefore not so reliable. The optimization results show that the parameter C_L is about 25% higher for Raschig Super-Ring 0.6 than for Raschig Super-Pak 250 Y. As the resistance against the mass transfer is concentrated in the liquid phase, Raschig Super-Ring 0.6 seems to be a more suitable packing for the physical absorption of CO₂ for the specific hydraulic conditions tested in the pilot plant.

However, the fitted values for C_L and C_V are approximately a factor 10 lower than the default values used in Aspen/Winsorp (Raschig's simulation tool). In other words, the pilot plant performance is below expectations. One explanation can be the occurrence of foaming in the absorber. A second possibility can be gas back-mixing as the gas velocity is very low and liquid can entrain the gas. As no clear evidence for either of these hypotheses is present, it may be recommended for the design of the large-scale plant to apply a higher gas velocity to avoid the risk of back-mixing and add some anti-foam to ensure that the mass transfer is optimal.

The trends in CO₂ absorption efficiencies with the change of the process variables (mass flows, concentrations, temperatures, pressures) are predicted correctly by the model (see Fig. 7). The CO₂ absorption efficiency is slightly underestimated (in reference state) which results in a safe prediction for up-scaling. For the full-scale plant, the process conditions may be outside the validated range e.g. absorber pressure up to 40 bar and solvent temperatures down to 10°C. The CO₂ absorption efficiency at higher pressure is overestimated which can be resolved by refitting the VLE data for the right pressure range. The CO₂ absorption efficiency at lower temperature is slightly under predicted by the model.

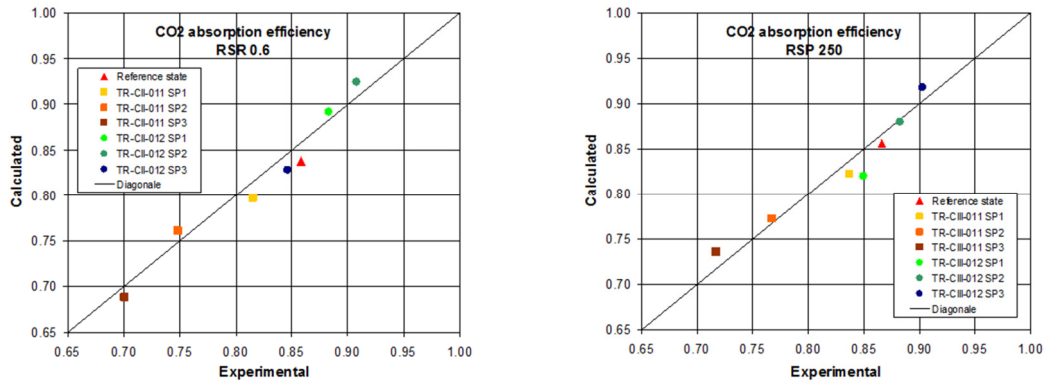

Fig. 7. Comparison of the experimental and calculated CO₂ absorption efficiency for test runs changing the solvent and syngas mass flow. Raschig Super-Rings 0.6 (left) and Raschig Super-Pak 250 Y (right)

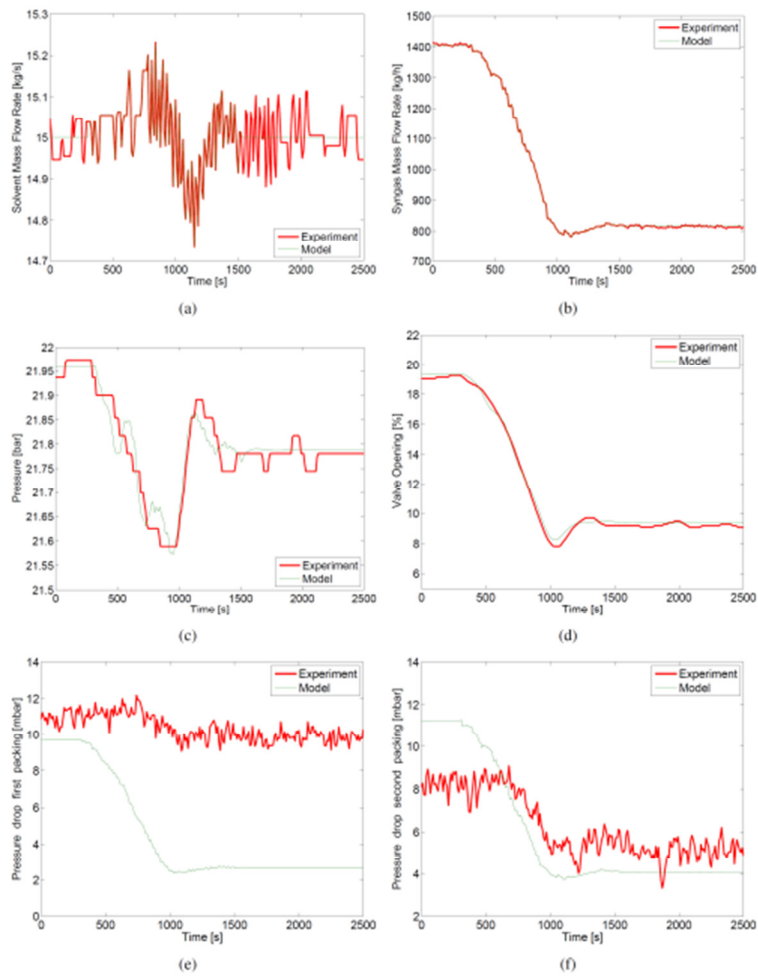

Fig. 8. Comparison of measurements and simulation results for a perturbation in syngas mass flow (Raschig Super-Pak 250 Y)

4.2. Dynamic model of the CO₂ absorption section

In order to study the transient performance of the pre-combustion CO₂ capture unit during load variations dynamic models of the (WGS and) CO₂ absorption section have been developed. The models are developed following a state-of-the-art, object-oriented, lumped-parameter modelling approach, using the open-source Modelica language implemented in a commercial software tool (Dymola) [5]. The CO₂ absorber model is validated by comparison with experimental data obtained from two open-loop transient tests in which the shifted syngas and solvent mass flow are perturbed. Satisfactory agreement between the experimental data and model predictions considering absorber pressure (see Fig. 8) and temperature and H₂-rich gas flow rate is achieved. The adopted holdup correlation can be used for predictions of the dynamic performance of the pilot plant absorber column. Hence, the validated model provides a reliable basis for the analysis of the transient performance of a large-scale absorber.

5. Conclusions

The CO₂ Catch-up project, aimed to demonstrate pre-combustion CO₂ capture at the pilot plant in Buggenum and to generate knowledge in the form of validated models and operational experience, has been finished successfully. The pilot plant has been operated without major problems and the overall pilot plant performance is according expectations. The results of the test programme show that there is still improvement potential in the energy consumption of conventional water-gas shift technology by further reduction of steam/CO ratios. Steady-state and dynamic pilot plant models have been validated successfully and can be used for future design and operational support of full-scale CO₂ capture plants.

Acknowledgements

The work documented in this paper has been performed within the CO₂ Catch-up R&D programme aimed at demonstrating and optimising pre-combustion CO₂ capture technology for the energy sector. This program is executed in a consortium of Nuon/Vattenfall, ECN and TU Delft and has been supported financially by the Dutch Ministry of Economic Affairs (“regeling EOS: unieke kansen regeling uitgevoerd door Agentschap NL”). All researchers involved in the project, the O&M team at Buggenum, the engineers of CB&I Lummys and CATO-2 are gratefully acknowledged.

References

- [1] Rostrup-Nielsen J.R., Sehested J. Hydrogen and synthesis gas by steam- and CO₂ reforming. *Advances in Catalysis*, 47, 2002, 65–139.
- [2] Damen K., Gnutek R., Kaptein J., Nannan N.R., Oyarzun B., Trapp C., Colonna P., van Dijk E., Gross J., Bardow A. Developments in the pre-combustion CO₂ capture pilot plant at the Buggenum IGCC, *Energy Procedia*, 4, 2011, 1214–1221.
- [3] Trapp C. Advances in model-based design of flexible and prompt energy systems, the CO₂ capture plant at the Buggenum IGCC power station as a test case, Ph.D. thesis TU Delft, Ipskamp Drukkers, The Netherlands, 2014
- [4] van Dijk H.A.J., Damen K., Makkee M, Trapp C. Water-gas shift (WGS) operation of pre-combustion CO₂ capture pilot plant at the Buggenum IGCC, submitted to *Energy Procedia*.
- [5] Billet R. and Schultes M. Predicting Mass Transfer in Packed Columns. *Chem. Eng. Technol.* 1993, 16, 1.