



# › DORA @ PLANT ONE

CATO day

**TNO** innovation  
for life

# DORA @ PLANT ONE

The problem:

- Solvent degradation
- Corrosion
- Emissions

- (a) EnBW's pilot campaign;
- (b) TNO's pilot campaign;
- (c) CSIRO's Loy Yang Campaign; and
- (d) Esbjerg pilot campaign

S. Dhingra *et al.*, "Understanding and Modelling the Effect of Dissolved Metals on Solvent Degradation in Post Combustion CO<sub>2</sub> Capture Based on Pilot Plant Experience," *Energies*, vol. 10, no. 5, p. 629, May 2017.

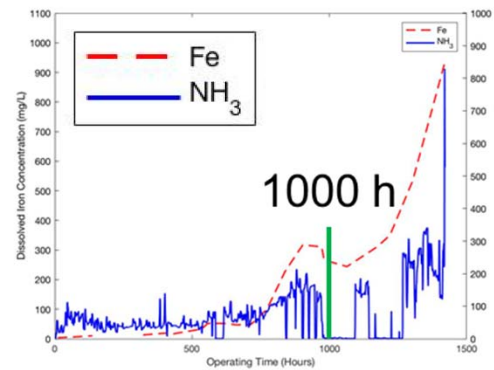

(a)

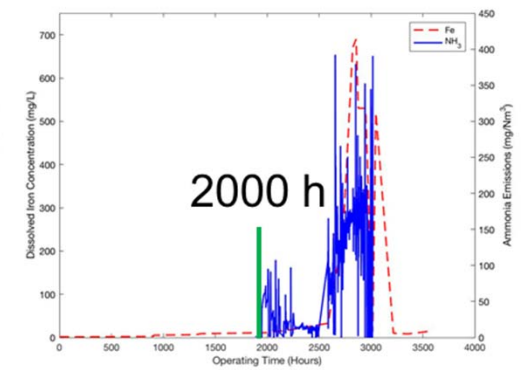

(b)

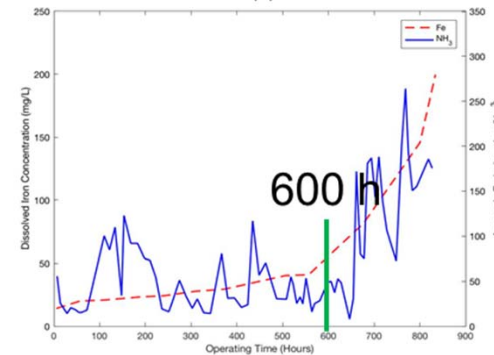

(c)

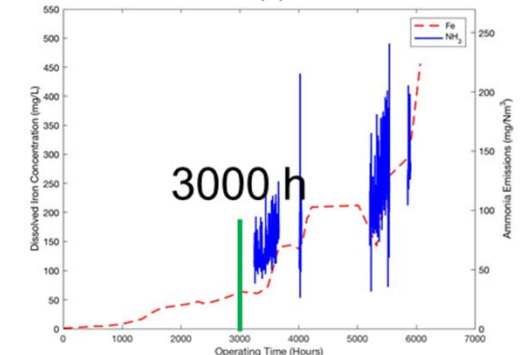

(d)

# DORA @ PLANT ONE

## Dissolved Oxygen Removal Apparatus

Goals:

- Reduced solvent losses
  - Lower emissions
  - Reduced waste
- Lower CO<sub>2</sub> capture cost

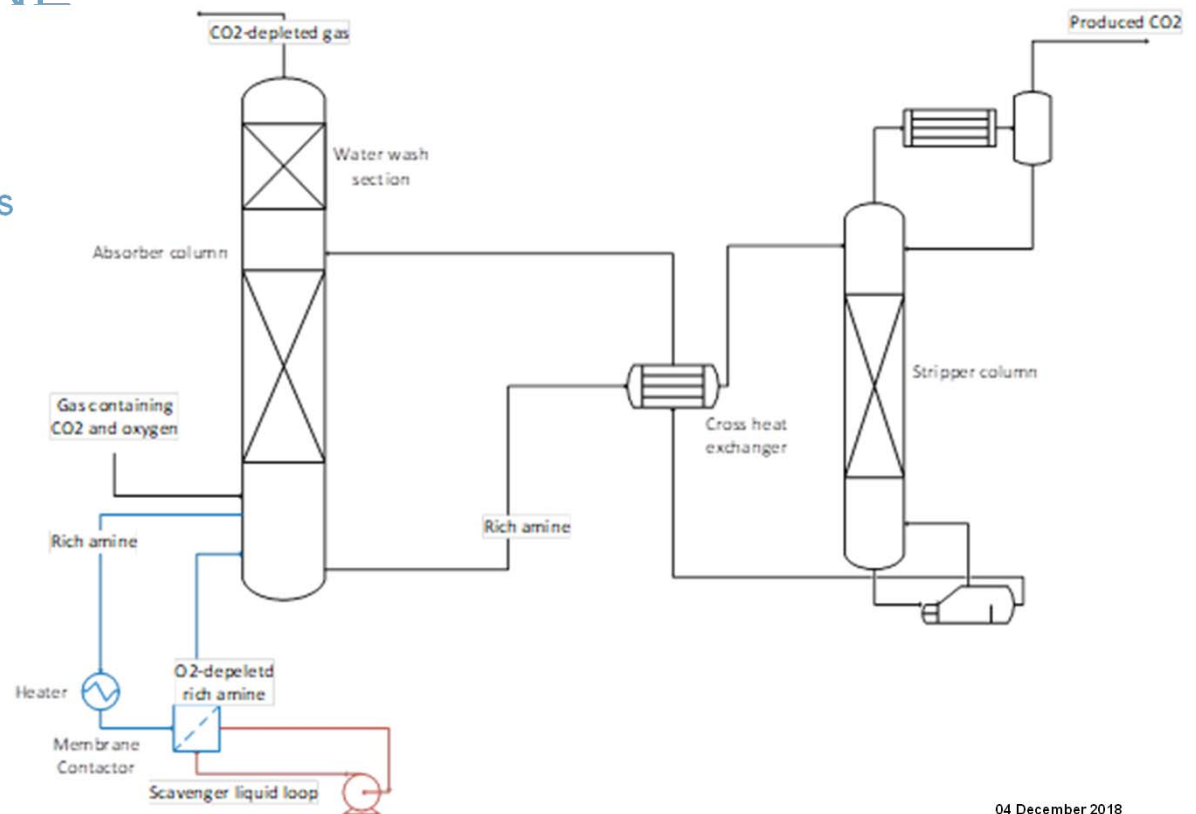

# CURRENT STATUS OF DORA: TRL4

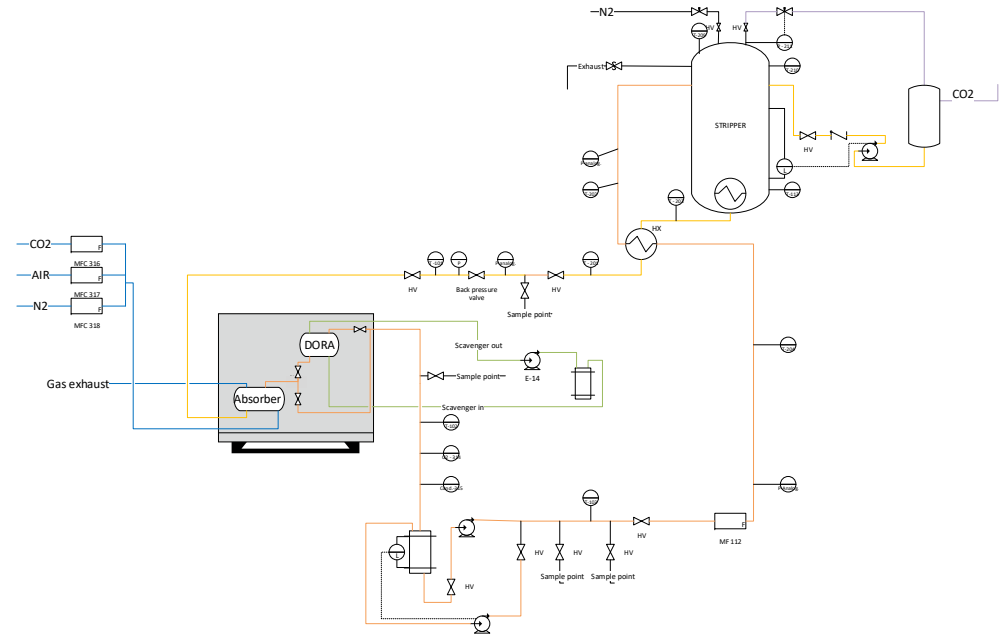
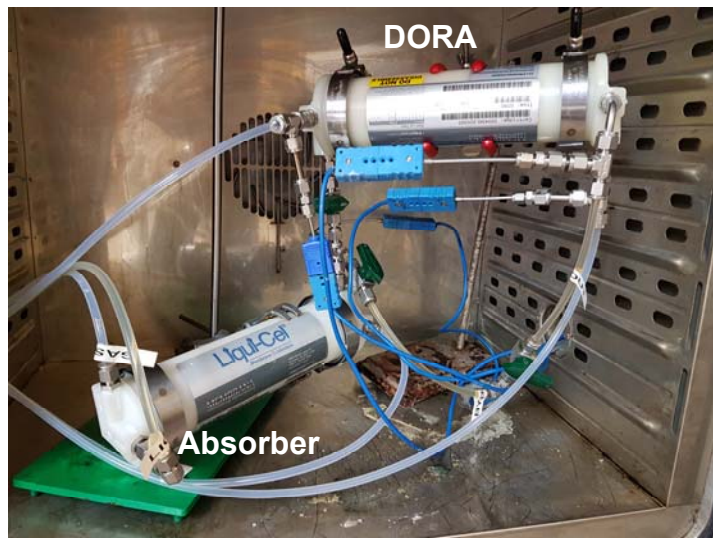

# SAMPLE RESULTS

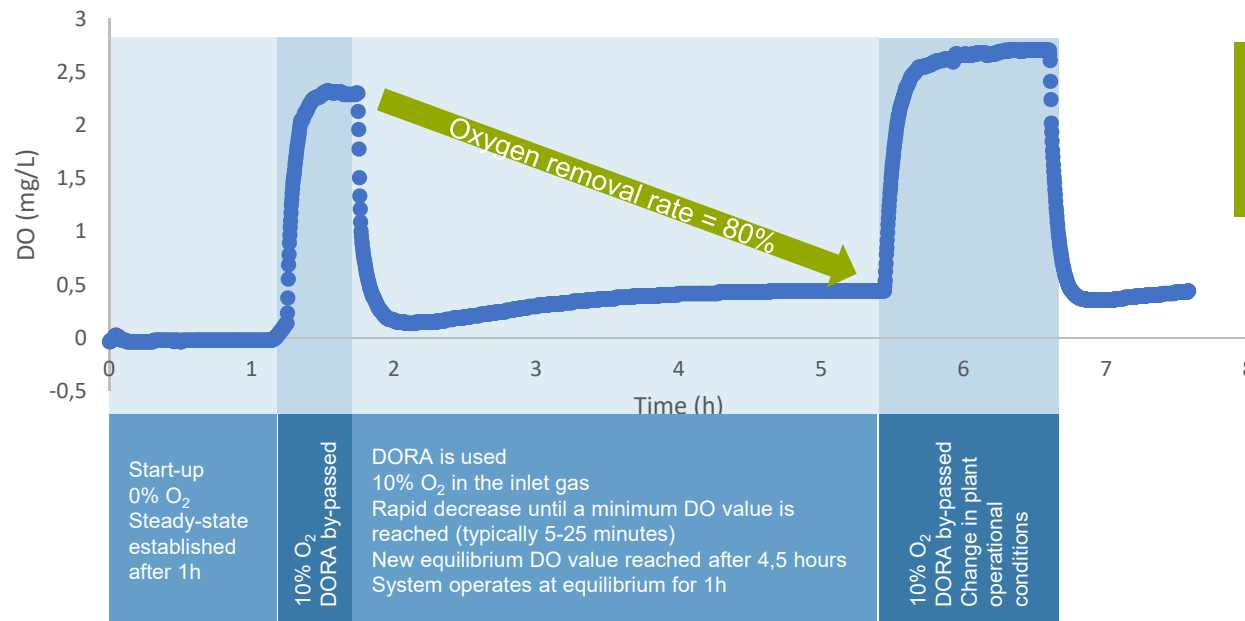

scavenger: aqueous sodium sulphite solution + copper catalyst

## EXPECTED IMPACT

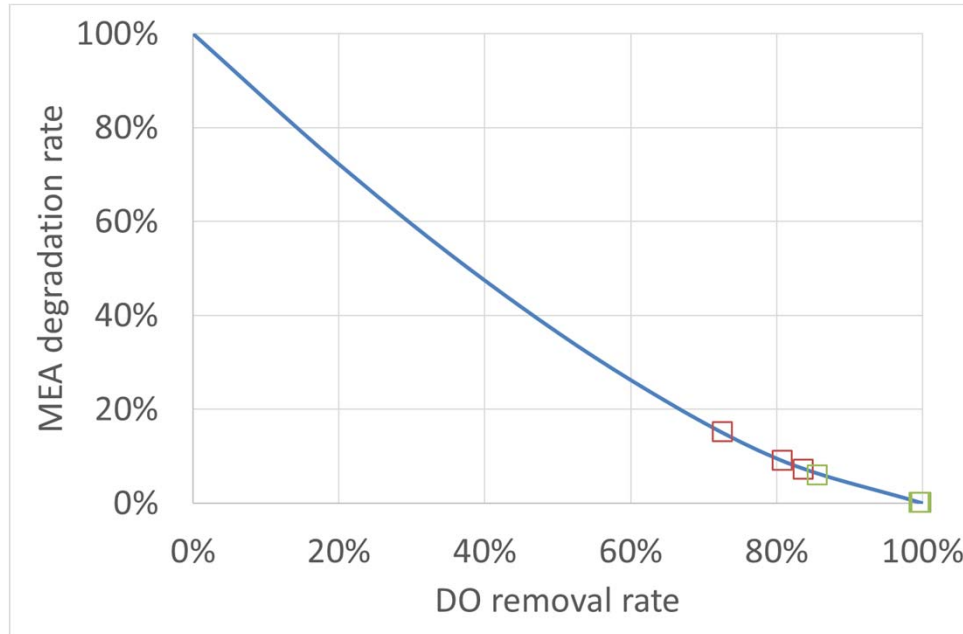

$$-r_{MEA} \propto [O_2]^{1,46}$$

Leonard, G.; Toye, D.; Heyen, G. Experimental study and kinetic model of monoethanolamine oxidative and thermal degradation for post combustion CO<sub>2</sub> capture. Int. J. Greenh. Gas Control 2014, 30, 171–178.

## 4 WORK PACKAGES

WP1 Design  
modifications

WP2 Retrofit  
DORA

WP3 Pilot  
campaigns

WP4  
Upscaling

## 4 WORK PACKAGES



Tested with artificial flue gas

Tested with real flue gas  
Long term effects measured



# WP3 - CAMPAIGNS

Baseline campaign

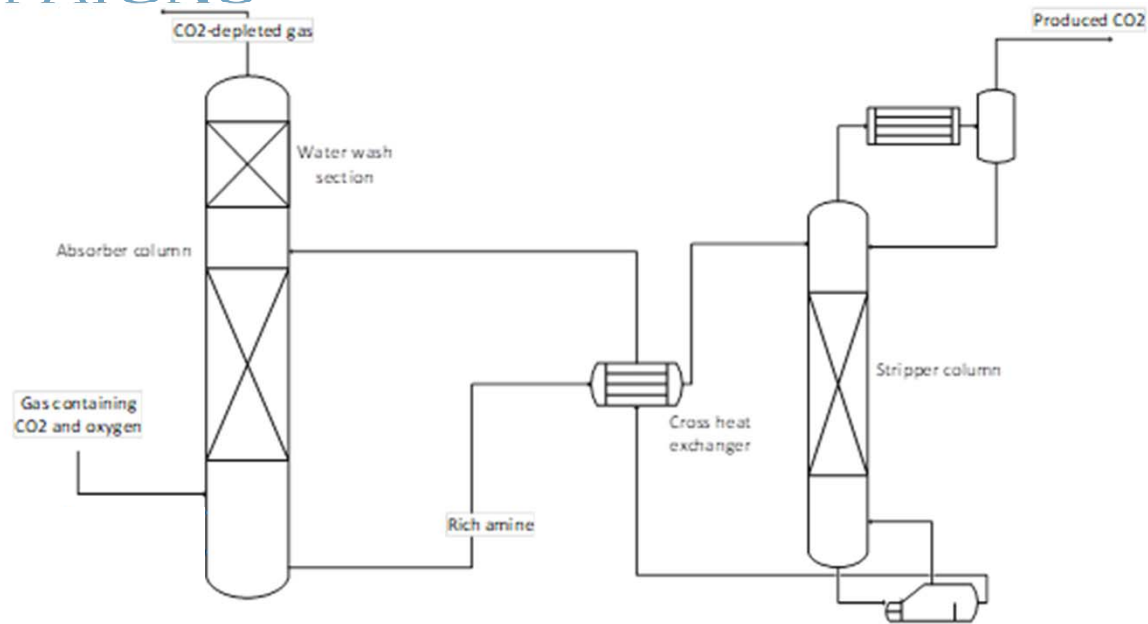

# WP3 - CAMPAIGNS

DORA  
Scavenger mode  
campaign

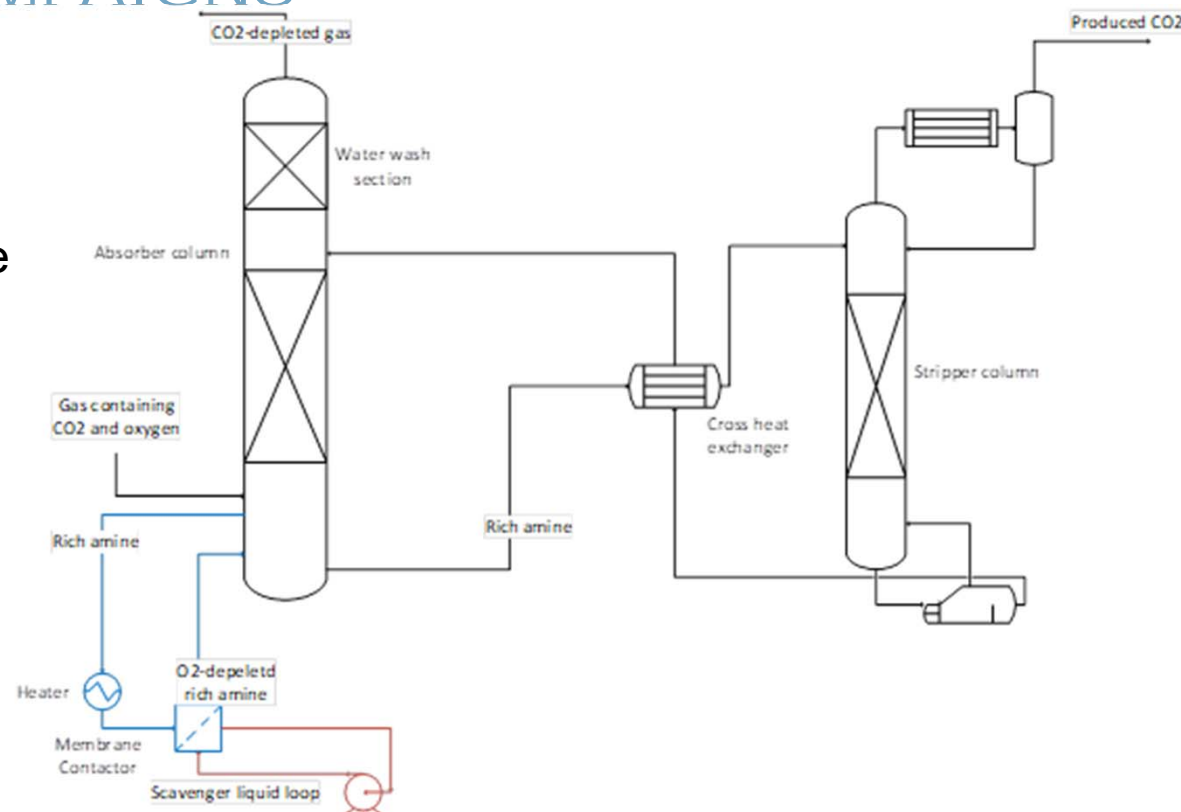

# WP3 - CAMPAIGNS

DORA  
Gas mode  
campaign

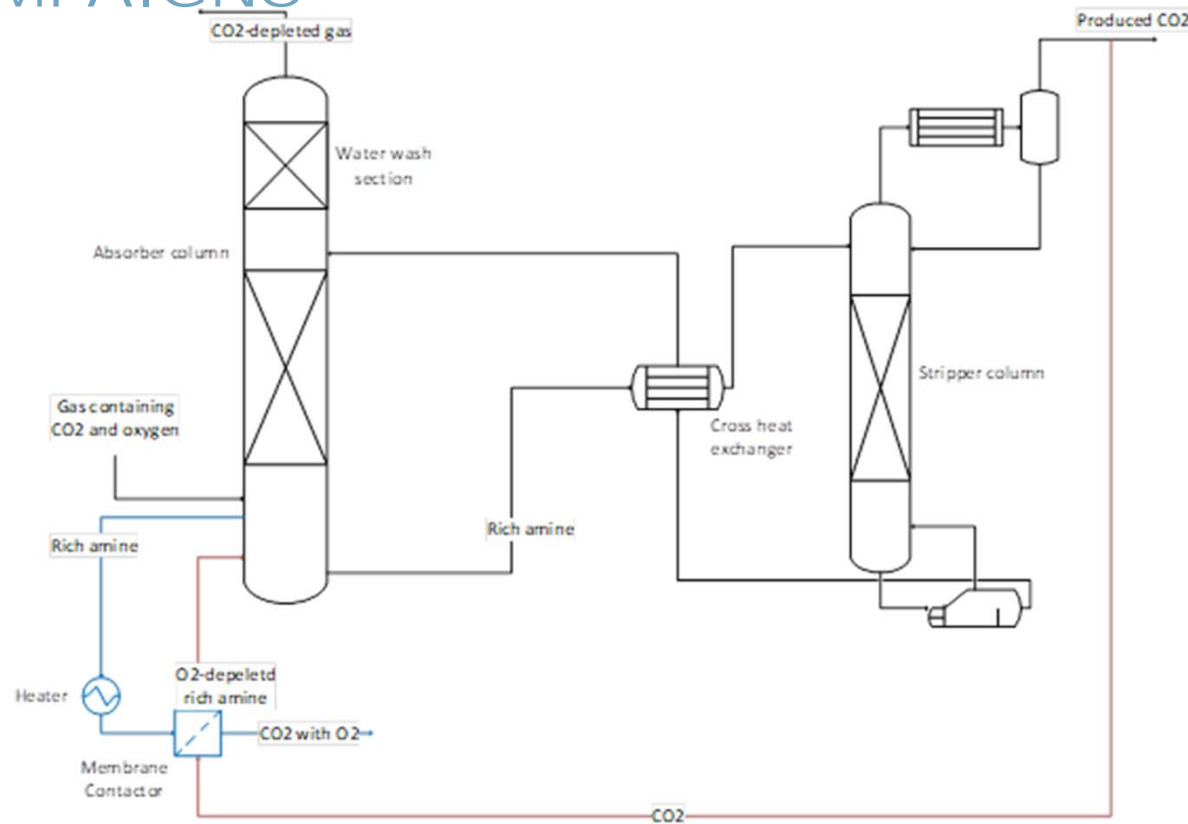

## WP3 - CAMPAIGNS

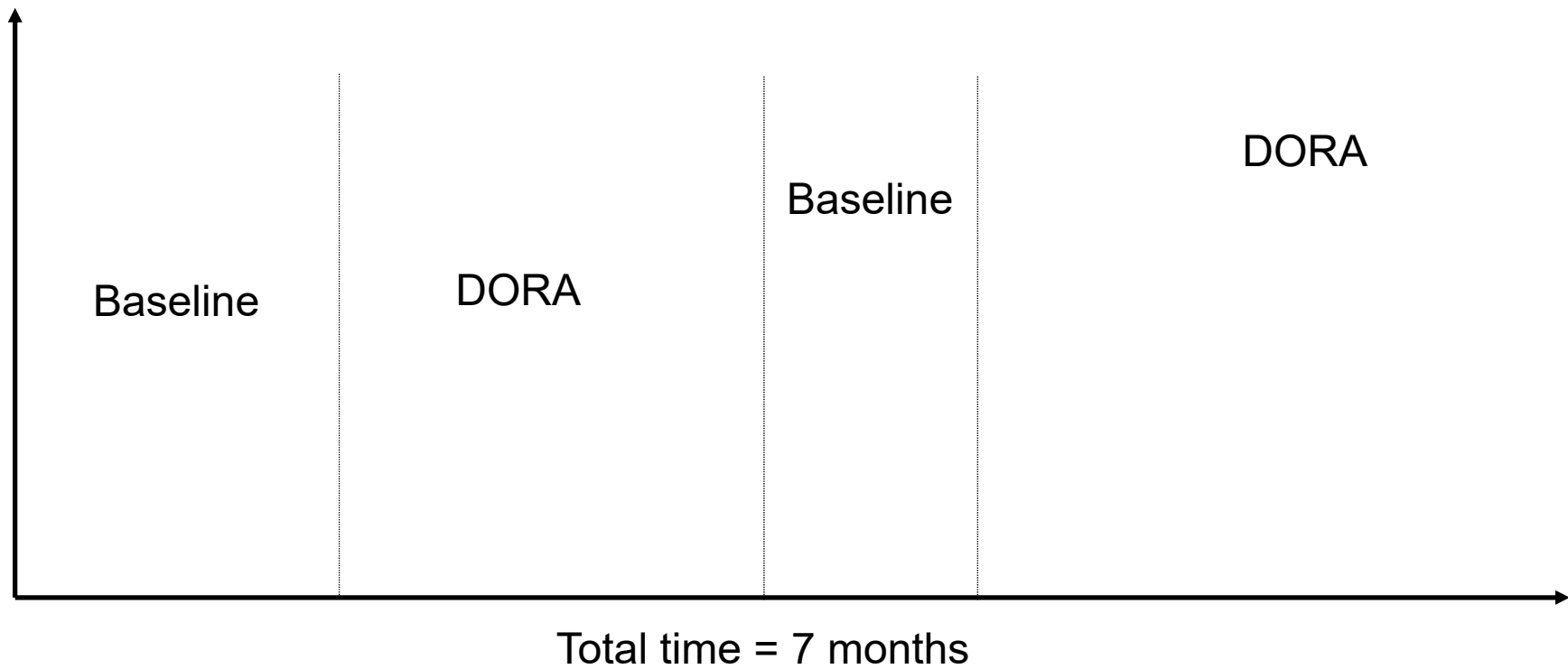

## WP3 - CAMPAIGNS

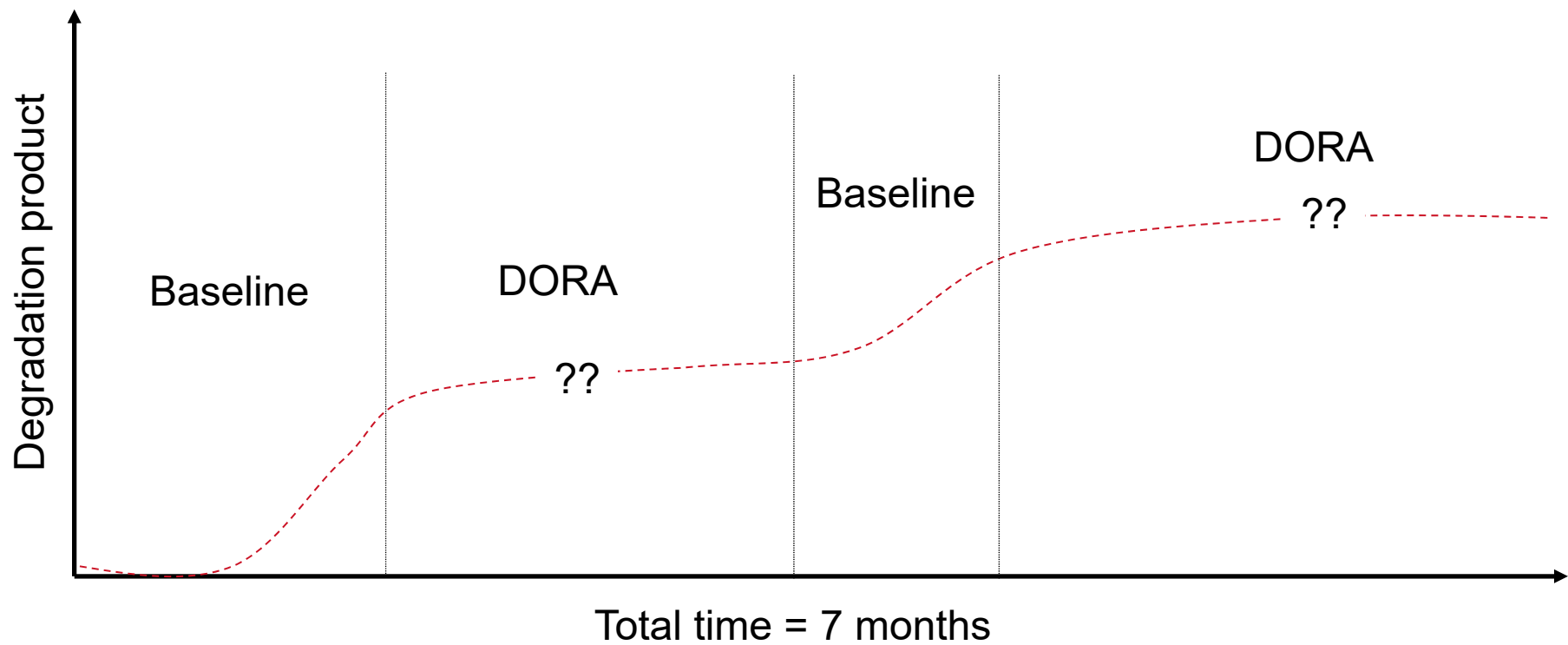

A nighttime photograph of a city street. On the left is a multi-story brick building with lit windows. On the right is a modern building with a curved facade and lit windows. A long-exposure light trail of a green vehicle is visible, curving across the street. The sky is dark, and streetlights are visible.

› THANK YOU FOR YOUR  
ATTENTION

**TNO** innovation  
for life

**Twence**®

[Juliana.Monteiro@tno.nl](mailto:Juliana.Monteiro@tno.nl)